



## LUMENEM™ 90

Another Lumenrail® System  
for Life Safety and Light

©2019 John Bartelstone

## LUMENGEAR™ EMERGENCY BATTERY BACK-UP

This Lumenrail system matched, listed component assembly, pairs our standard driver with a mating emergency controller/ battery component to achieve egress code compliance. The 90 minute run-time, lumen delivery under emergency operation and integrated illuminated test switch meet or exceed NFPA 101 7.9.1, 7.9.2 and 7.9.3.

*Available by request: We offer a 240 minute run-time version, developed in conjunction with the New York City Transit Authority.*

- **Fully wired listed system for use with Lumenrail, Lumenlinear fixtures only**
- Locking, painted steel NEMA 4X enclosure
- 100W, 120-277V, 24VDC driver
- Matched controller/battery unit
- Integrated LED indicator/test switch



PROJECT NAME: \_\_\_\_\_

REP AGENCY: \_\_\_\_\_

APPROX. LINEAR FT: \_\_\_\_\_

SERVICE OPTIONS:  Field Measure     Job Site Support     System Installation

## SYSTEM SPECIFICATIONS

### LUSYSEM 90 COMPLETE EM SYSTEM



All electrical connections to be made by a qualified electrician in accordance with all national, state and local electrical codes.

- ENCLOSURE (LUENCLOSURE4XBUD15) NEMA 4X, IP65, powder-coated, locking (2keys), gasketed, welded steel enclosure 15.75" X 11.81" X 5.91
- DRIVER (LUDRIVERDM100WACE) -Driver, 100W 24VDC Output, 120V-277 Input, 1-10V PWM Dimming
- CONTROLLER / BATTERY (LUEMCNTBATIG20ACE) - Constant power backup, current input range of 363mA-1330mA, input voltage in the range of 15-55 VDC, listed Class 2 UL 924
- LED INDICATOR / TEST SWITCH - (Integrated harness assembly)
- PERFORMANCE - Capability to achieve code compliant lumen output for a minimum of 90 minutes, with up to 40' of our Lumenlinear™ fixtures. Run lengths are dependent on fixture wattage specifications.

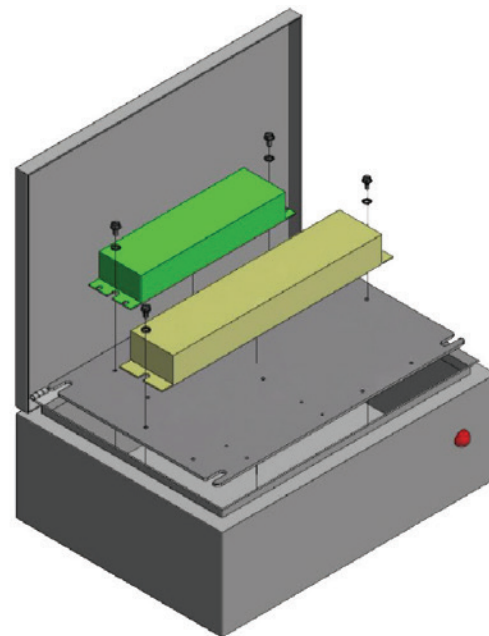

## OPTIONAL EQUIPMENT

### DIMMING PROTOCOLS

- LUCNTDALIELD Lumenrail Dali Controller Kit, 8A, EldoLED LINEARdrive 210D
- LUCNTDMXELD Lumenrail DMX Controller Kit, 8A, EldoLED LINEARdrive 212D

### FUSING

- LUFUSEKIT2 Lumenrail Dual Fuse Kit, Bussmann Fuse Holders, Mounting Bracket, 6A Fast-Acting Fuses for 100W/24VDC Driver and EM Controller/Battery unit

### SURGE PROTECTION

- LUSURGKIT Lumenrail Surge Protector Kit, TRP SSP3-277 20kASurge Protector 120-277V and Mounting Bracket

The Lumenrail® Architectural Systems LumenEM enclosure is approved to hold:

- One standard 100W driver and one EM controller / battery unit
- **AND**
- One Dali or DMX dimming controller **AND**
- One Dual Fuse kit per enclosure **OR**
- One Surge Protection Kit per Enclosure.

All of the LumenEM systems are UL8750 listed and can be used in these combinations, with Wagner Architectural Systems Lumenrail Lumenlinear fixtures only. Not all options apply to all products, please verify compatibility with the factory. All LumenEM Emergency Battery Back-Up Systems come fully assembled from the factory and are made-to-order per specification.

@wagnercompanies

## **EMERGENCY EGRESS LIGHTING**

In buildings where artificial lighting is provided for normal use and occupancy, exit lighting and the illumination of the means of egress is required to ensure occupants can quickly evacuate the building.

Emergency lighting (1-foot candle average; 0.01-foot candle minimum) must be provided for a period of 1.5 hours in the event of failure of normal lighting. The emergency lighting system must be arranged to provide the required illumination automatically in the event of any interruption (10 seconds) of normal lighting, such as any failure of public utility or other outside electrical power supply or opening of a circuit breaker or fuse. Either the emergency lighting system must be continuously in operation or capable of repeated automatic operation without manual intervention. All emergency lighting must be installed and tested in accordance with NFPA 111 (Full 1.5 hour test annually and 30-second test every 30 days.)

### **NFPA 101 7.9.1 General**

Emergency lighting is required for all means of egress, including both the exits and the pathways leading to them. This includes stairs designated for emergency exit as well as the aisles, corridors, ramps, escalators and other passageways that lead to an exit. This requirement also extends to exit discharge points, which include stairs, ramps, aisles, walkways, and escalators leading to an area open to the public. 7.9.1 GENERAL

### **NFPA 101 7.9.2 Performance of System**

This section specifies the requirements for how bright emergency lighting must be and how long it must be provided in the event of failure of normal lighting. In the first 1.5 hours after a failure, emergency lighting must provide an average of one foot-candle and no less than 0.1 foot candle at any point along the path of egress.

After 1.5 hours, the illumination level may decline. However, because the Code requires a maximum-to-minimum illumination ratio of no more than 40 to 1, the illumination may only decline to an average 0.06 foot-candle, no less. The Code requires that emergency lighting be provided automatically in the event of a power failure resulting from power outages, blown fuses or circuit breakers, or manual acts that result in an interruption in normal lighting. Given this requirement, emergency power supply systems (EPSS) – the systems that power your emergency lighting system – are also addressed in this section, mostly by reference to other NFPA codes. Citing NFPA 110, it states that new EPSS must be Type 10, Class 1.5, Level 1 and refers to NFPA 110 and 111 for the installation, and maintenance of EPSS – emergency generators and their related transfer switches and stored electrical energy systems, respectively.

### **NFPA 101 7.9.3 Periodic Testing of Emergency Lighting Equipment**

The Code provides three options for periodic testing of your emergency lighting equipment and another option pertaining to testing of your EPSS. The option you choose for testing your emergency lighting system will depend on the type of system you have – whether it is or is not a battery-operated, self-testing and self-diagnostic system and if it is, whether or not is computer controlled.

Regardless of the type of system you have, it must be tested for a duration of 30 seconds, generally, once every 30 days and annually for a duration of 1.5 hours. Additionally, all emergency lighting must be fully operational throughout the duration of all tests conducted.

Testing for battery-operated, self-testing and/or self-diagnostic systems should include a diagnostic routine. For systems that are not controlled by computer, you must perform visual inspections once every 30 days, and your system must be equipped with a status indicator to alert you to any failure.